



**ENGINEERING AND MANUFACTURING
CENTER
«SKB UKRELECTROMASH»**



UPEC INDUSTRIAL GROUP

The UPEC Industrial Group is one of Ukraine's largest private companies, occupying a leading position in several product segments and in production of components.

STRATEGIC OBJECTIVE

To create a new generation of globally competitive high-tech products, which will provide sustainable development of the Company and prosperity growth of its personnel.

UPEC is one of the CIS leading manufacturers of bearings, electric motors, pumps, CNC grinding machines, transmissions and chassis, air-cycle climate control systems, trailed agricultural machinery, as well as other machinery, equipment, units and components for the railway, automotive, agricultural, general and power engineering, defense, metallurgical and other industries.

The Company was established in 1995, and today it unites a number of leading manufacturing companies and engineering centres with more than half a century of history.

The main know-how of the Company is generated in the UPEC Joint Engineering Centre, which includes a number of specialized engineering centres and departments.

The main manufacturing sites of the UPEC Industrial Group:



Kharkov Bearing Plant (**HARP**) — manufacture of energy-efficient bearing units and «cartridge» bearing products;



Oskol Bearing Plant **HARP** — international localization of HARP, manufacture of a new generation of bearing products;



Lozova Forging-Mechanical Plant (**LKMZ**) — manufacture of cold- and hot-forged components, transmissions and trailed agricultural machinery;



Kharkov Electro-Technical Plant Ukrelectromash (**HELZ**) — manufacture of induction electric motors, a wide range of electric pumps and other consumer products;



Kharkov Machine-Tool Plant (**Harverst**) — manufacture and refurbishment of roll and cylindrical grinding machines, as well as special-purpose grinding machines for the bearing industry;



Ukrainian casting company (**ULK**) — manufacture of steel and iron casting.

The products of the UPEC Industrial Group are presented on the market by the divisions: Railway, Automotive, Electro-Technical, Machine-Tool and Agricultural.

Each division offers consolidated product supply from all the companies of the Industrial Group, which can be used in this market segment.

The divisional structure allows us to meet the needs of our customers to the fullest extent, as we are able to focus all of the Industrial Group's engineering, design and manufacturing resources on the task set by the customer.

DIVISIONS

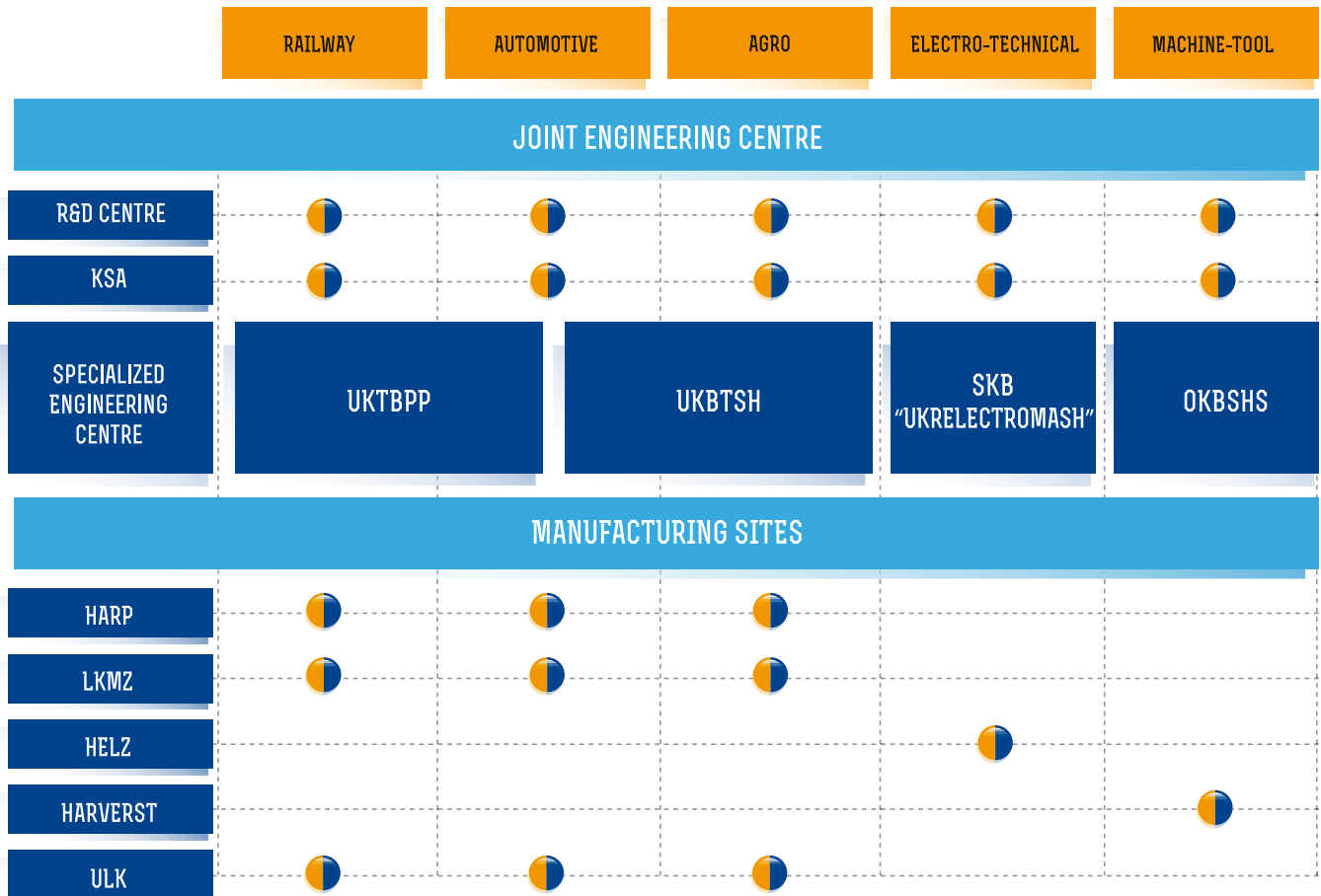

The **Railway Division** supplies components for the production and maintenance of rolling stock to the transport engineering companies.

The **Automotive Division** provides the leading assembly-line companies of automotive, agricultural and road-construction machinery with bearings, units and components.

The **Electro-Technical Division** supplies induction electric motors, electric pumps of general and special purposes, including borehole pumps and feed cutters for livestock farming.

The **Machine-Tool Division** develops, manufactures and upgrades roll and cylindrical grinding equipment for metallurgy and other industries.

The **Agricultural Division** provides the market with the advanced high-performance and energy-efficient agricultural machinery for modern resource-saving cultivation technologies.

There are plans in place to establish an Industrial Division, a Special Machinery Division and a Division of Renewable Energy.

JOINT ENGINEERING CENTRE

The Joint Engineering Centre (JEC) was established to implement the UPEC Industrial Group's new strategy, focused on the priority of engineering knowledge, development and manufacture of innovative products with a high intellectual level and, as a result, high value added.

The Centre is equipped with powerful computing resources, advanced software systems, knowledge bases, while the JEC staff, most of whom are Doctors and Candidates of Science, have unique experience in conducting sophisticated research for aerospace and defense industries, energy and transport engineering, as well as other sectors of the industry.

The Joint Engineering Centre is headed by Dr. Eduard Simson, R&D Director, Deputy General Director of UPEC, Professor, Laureate of the State Prize of Ukraine in Science and Technology, Member of the Academy of Engineering Sciences of Ukraine, Honoured Scientist of Ukraine, author of more than 200 scientific articles and monographs in the field of optimization of complex structures under dynamic loads.

The UPEC JEC supports all specialized engineering centres with the most complex fundamental and applied research. It generates know-how for the company and centers its intellectual property.

One of the most important tasks of the JEC together with the marketing and sales departments is selection, verification and engineering support of the competitive advantages to be put during the product planning stage, ensuring that products are of the highest possible technical level, offering optimal operating parameters, durability, long service life, energy-efficient operation.

JEC cooperates actively with the largest universities, specialized scientific research institutes and international high-tech companies. In close cooperation with the engineering services of the customers, it successfully improves traditional products, develops and introduces innovations.

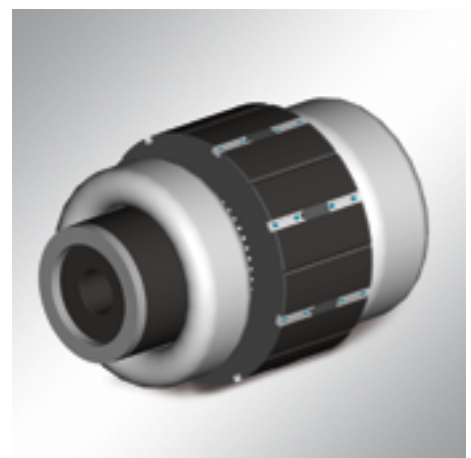

INTELLECT EMBODIED IN METAL

The UPEC JEC provides services to international customers in conducting complex 3D nonlinear strength, dynamic, thermal, electromagnetic calculations and multi-criteria optimal design of structural elements. The UPEC's partners rely on JEC services for mathematical simulation and optimal design of the elements and units in their products, as well as for simulation and optimization of basic technological processes for product manufacturing (casting, hot and cold forging, rolling, heat treatment with phase transformations and hardening, including hardening with induction heating, etc.).

THE JEC STRUCTURE INCLUDES:

- The Centre for Mathematical Simulation of Designs and Technological Processes and for Optimal Design of Machine Parts and Assemblies (R&D Centre);
- The Centre for Integrated Engineering Automation (implementation of the largest project of integrated electronic environment management of design and technological developments in Eastern Europe and the CIS, based on the PTC software platform, USA);
- The Group for intellectual property management, technology transfer and outsourcing with the leading international engineering companies;
- The Ukrainian Bearing Industry Design and Technology Bureau (UKTBPP);
- The Ukrainian Transmission and Chassis Design Bureau (UKBTSh);
- The Experimental Design Bureau for Grinding Machines (OKBShS);
- The Special Design Bureau for Electrical Engineering («SKB Ukrelectromash»);
- The Air Turbo Technology Department (ATT Engineering Centre);
- The Department of Hydrostatic and Hybrid Transmissions.

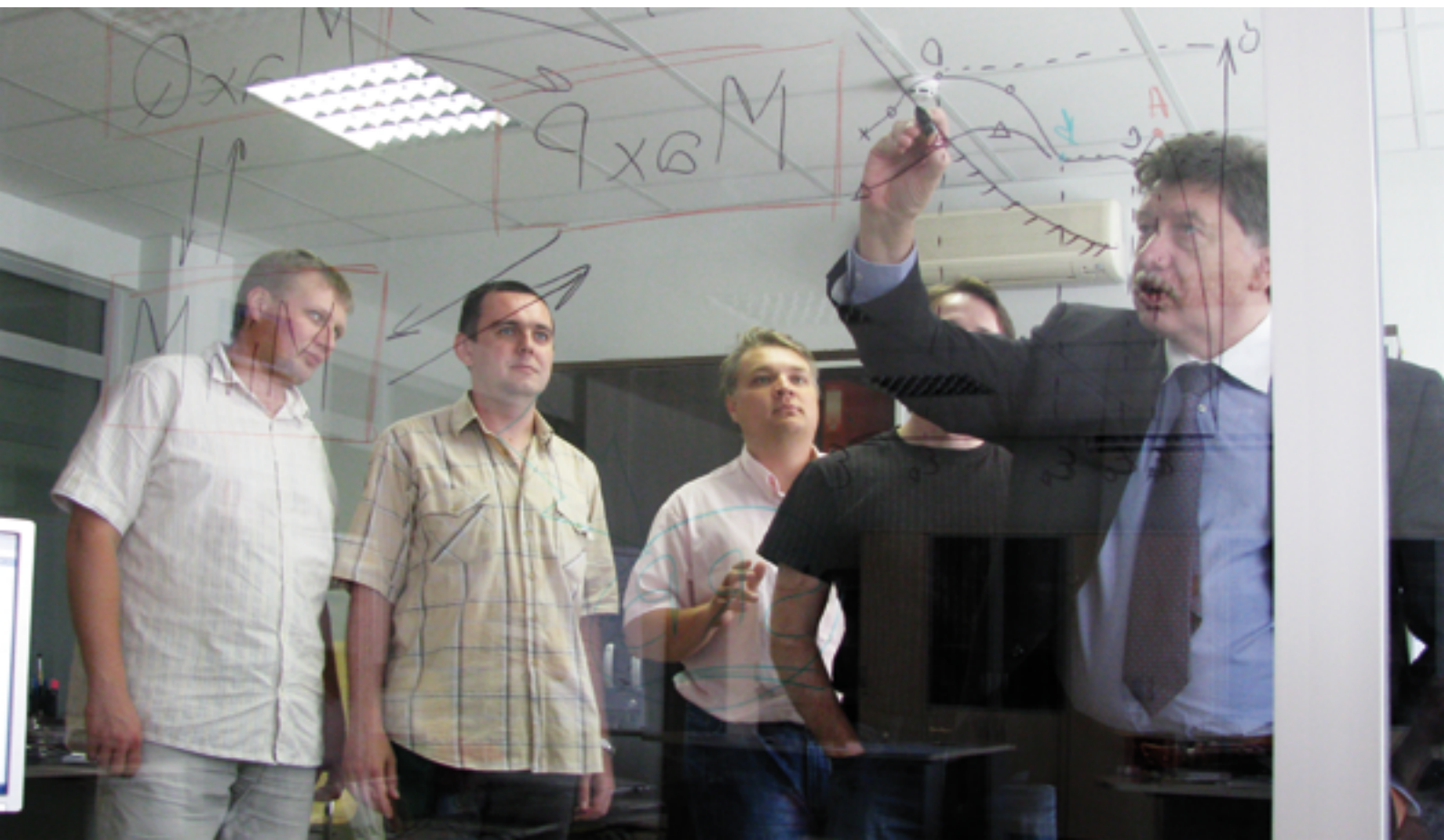

ENGINEERING CENTRE «SKB UKRELECTROMASH»

The Engineering Centre «SKB Ukrelectromash» specializes in the development of new electric motor designs, including special-purpose motors, generators, variable frequency drives, water pumps, electric compressors, electric fans and other devices integrated with an electric drive.

One of the most important activities of the SKB is design support of high-volume production of Kharkov Electro-Technical Plant (HELZ), modernization of its product lines and extension of the product range, as well as restructuring of its production on the base of outsourcing.



HELZ «Ukrelectromash» is Ukraine's largest manufacturer of induction electric motors and electric pumps, based on the SKB design documentation. HELZ has a closed production cycle: stamping, casting (nonferrous die-casting and chill casting), machining, winding, assembling, painting, testing and packing.

«SKB Ukrelectromash» is the developer and manufacturer of low-noise and low-magnetic electric motors with unique design, electrical, mechanical and other parameters for application in the life support systems of submarine and surface vessels of civil and military purposes, in the railway locomotives, at nuclear power plants and in air defense systems.

Technical archive of the Company comprises 156 current specifications for the in-house design products, enabling the manufacture of over 2000 electro-technical product types.

Up to the present day, a lot of CIS electric engineering companies manufacture electric motors based on the SKB engineering documentation.

«SKB Ukrelectromash», a leading developer of electro-technical products and a reliable partner for numerous corporate customers, has an extensive practical experience in designing of special-purpose electric motors and solving the assigned tasks in a proper way and in due time.

The SKB has an up-to-date integral CAD/CAM/CAE software system of Pro/Engineer class and PDM/PLM packet of WindChill, integrated with a special software complex «SPRUT», for advanced calculations and performance of the assigned tasks.

The Testing Centre provides unique opportunities to the SKB Engineering Centre. The Engineering Centre is equipped with automatic test rigs and testing equipment of its own production. These rigs and equipment know no equals and allow to conduct comprehensive testing of single samples and small industrial batches.

TIMELINE



DEVELOPMENT AND IMPROVEMENT

Current electrical engineering trends — aspiration for energy efficiency, environmental sustainability, easy control and compact size — underlie the development of the «SKB Ukrelectromash» products.

The SKB develops new products and upgrades current ones increasing the performance and ensuring such customer-popular features as reliability, simplicity and low prices.

SERIAL PRODUCTION

- general-purpose industrial single and three-phase electric motors, variable frequency drives and energy-efficient electric motors
- centrifugal, vortex, jet, centrifugal well, submersible, household and industrial-purpose irrigation pumps
- root, seed, corn and farm grass cutters

SPECIAL-PURPOSE ELECTRIC MOTORS

«SKB Ukrelectromash» has a unique experience in the development of special-purpose electric motors with original design, electrical, mechanical and other parameters for max. power of 200 kW:

- for submarine and surface vessels with unrestricted navigation area
- for drives of fans, pumps, compressors and air conditioners, which can operate in any climate area, with variable frequency and separate ventilation
- for Nuclear Power Plants
- with power frequency of 50, 60, 100, 400 Hz
- for operation in rolling stocks
- built-in motors with freon and oil resistant insulation for air conditioners and refrigerating machines
- permanent magnet generators, including wind power generators
- AC converter-fed motors
- multi-speed and gearless variable frequency motors of elevator drives
- brake motors with a built-in or attached electromagnet brake

NEW DEVELOPMENT PROJECTS TO BE FINISHED SOON:

- high frequency motors with rotor speed of 20...40 000 rpm and power range from 20 to 50 kW
- electric motors for condensed gas transfer pump drives
- traction induction motors for tram and underground electric train drives
- pumps for in-situ leach mining of uranium ores

INTERNATIONAL COOPERATION

The SKB Engineering Centre constantly improves current procedures and develops new ones for electric motor and pump calculations.

For example, the SKB has close cooperation with Ukrainian leading universities (National Technical University «Kharkiv Polytechnic Institute»), foreign institutes of NIPTIEM (Scientific Research Design Engineering and Technology Institute of Electric Machine Industry), Russia, and Dr.-Ing. Braun Institute, Germany, in «electromagnetic core» optimization and in general choice of optimal design and materials. Methods of electro-magnetic, thermal and ventilation calculations of electric motors, as well as calculations for single-phase electric motors, were introduced within this cooperation in 2010-2012.

One of the main trends in modern electric machine industry is division into the development and assembly of new products by leading manufacturers, as well as manufacture of electrotechnical components, primarily, stator and rotor packs.

For the new look and new series of the HELZ electric motors, the SKB has made a lot of efforts to select international suppliers of components, which resulted in the partnership with leading European and Chinese manufacturers of high-quality lamination (stator and rotor packs). At the same time, electric motor design optimization and adaptation issues related to the difference in manufacturing technology have been solved. Joint work with engineers from the partner companies ensured technical level increase and product quality consistency.

In order to ensure design optimization and proper material application for high speed motors while establishing partnership with European companies, we applied electro dynamo steel with unique electromagnetic properties, which helped us to achieve the highest efficiency of 94% for the motors with speed range of 30 ... 40 000 min⁻¹.

EDEM PROJECT (KSA+SPRUT)

Design and development involve an up-to-date CAD/CAM/CAE/PDM/PLM software system «KSA», based on the PTC products (USA) and integrated with a special «SPRUT» (NIPTIEM) calculation software complex.

This project for design and technology automation allowed to equip over 30 working places of designers, engineers and other members of the «project team» with advanced calculating resources. Over 40 employees completed professional training and special additional training.

All designing and engineering activities of the Company are currently involved in «KSA-2008» business processes.

After receiving a task from the UPEC Marketing Research Centre together with the Joint Engineering Centre, designers take up product designing and engineering in the unified electronic environment. Designers conduct mathematical simulation and electric motor design modification; technologists confirm and amend design documents, as well as develop technology documents; CNC machine setup operators control management programs for pattern tooling; economists calculate and automatically receive data from the software complex for ERP system. This software complex also involves all the procedures of confirmation and approval.

SPRUT program for three-phase induction motor electromagnetic calculation is applied for:

- calculation of power and starting characteristics
- calculation of losses and equivalent circuit parameters with required geometry, winding parameters, voltage and supply frequency
- geometry drawing of the rotor and stator slots

This software method puts the values of rotor permeance, stator and rotor air gap factors, coefficients of casting technology directly into the initial data.

Values of losses in stator and rotor winding, as well as in steel, can be transmitted into the program for induction motor thermal and ventilation calculation.

The program is an integrated part of the calculation subsystem for induction motors. Induction motor calculation subsystem is the most significant component of the end-to-end design system in the integrated line:

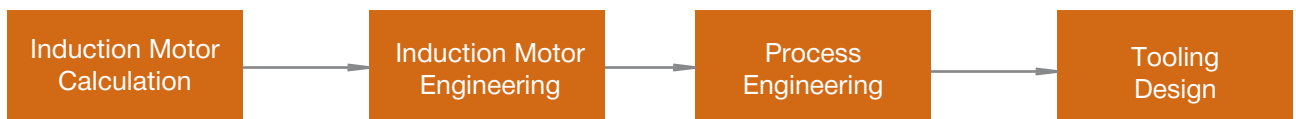
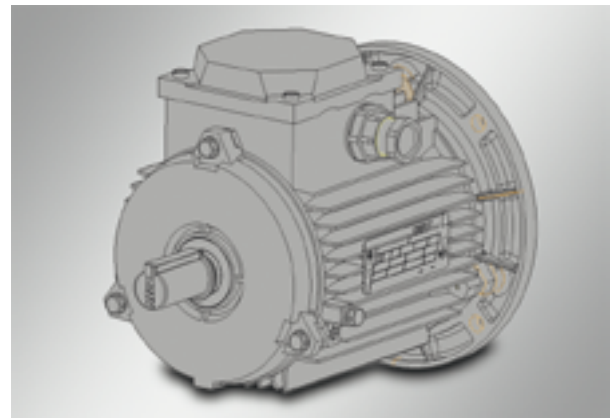

SPRUT program for induction motor thermal and ventilation calculation is applied for:

- calculation of average temperature rise in induction motor stator winding
- temperature rise determination of about 20 electrical machinery elements

Approval of a newly-designed motor compliance with electromagnetic and thermal loads is based on the results of thermal and ventilation calculations.

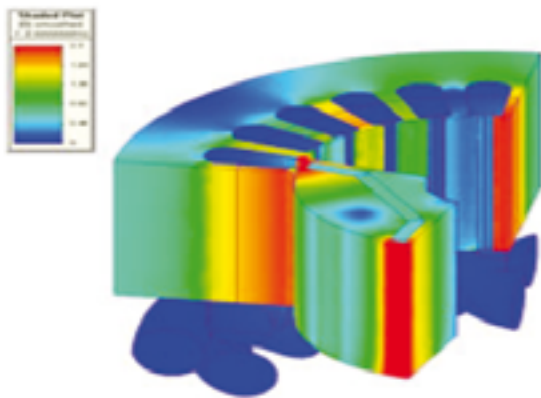

The SKB applies internationally recognized standards of CAD/CAM/CAE/Pro/ENGINEER integrated solutions, which provide the user with all the tools to reduce time and enhance the quality of engineering. Automated 3-D design tools can be successfully integrated with the best in the industry PTC solutions, which include: Windchill® for data and process management, ProductView™ for interactive visualization, Mathcad® for engineering updates of the «SPRUT» system and Arbortext® for dynamic document publication.

Windchill, the solution for Product Lifecycle Management (PLM), is applied for internet work in the distributed designing environment. Windchill provides cooperation of all team members in the new product development. Business process automation and corporate standards compliance helps decrease error rate in the developments and place all product data in the single protected storage medium, it also ensures error control relating to back-ups, manual and incomplete data transfer.

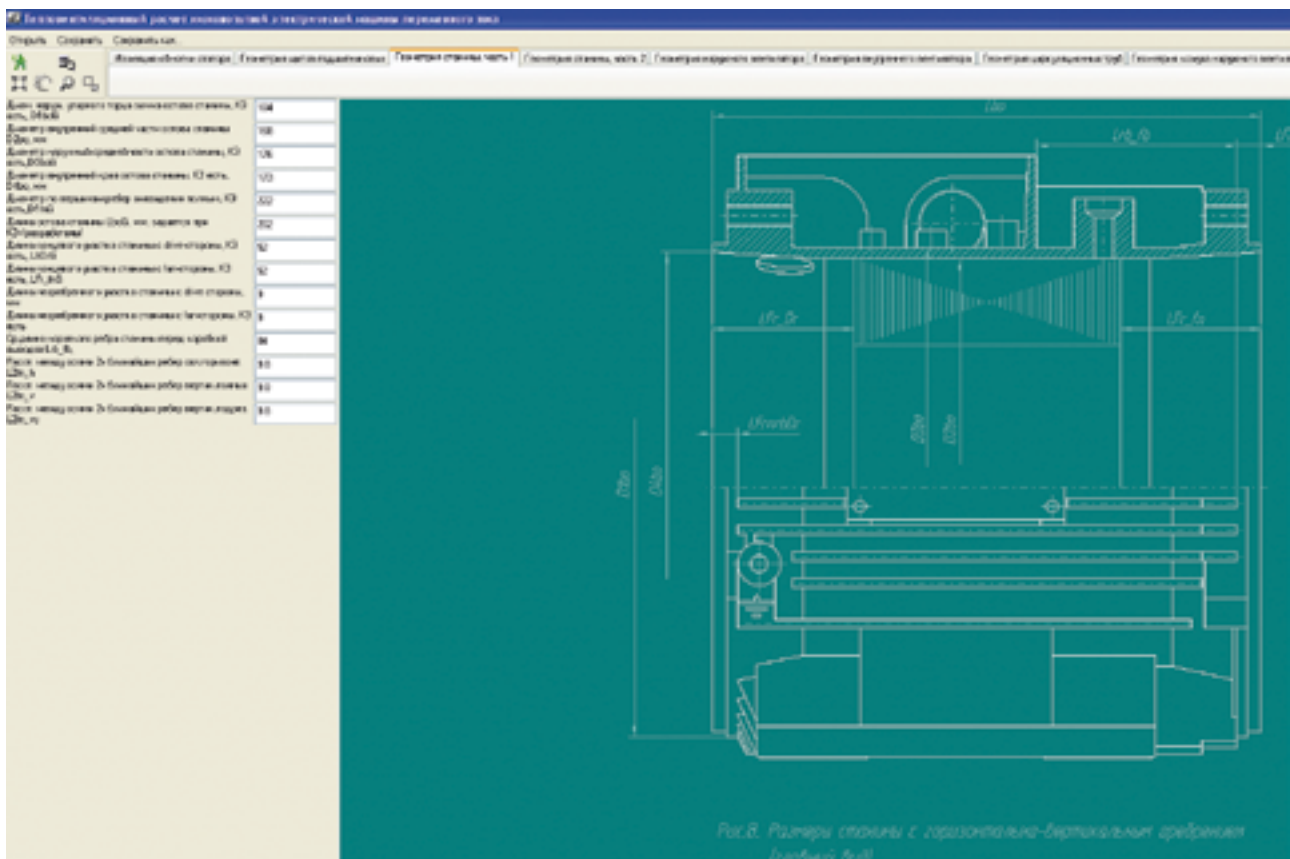

NEW PRODUCTS

In order to expand the product line, ensure continuous improvement of technical parameters and decrease product costs, the company pays a lot of attention to the development of new products and upgrading of current ones. New products for different industries have been recently developed to expand the current product line.

SUPER HIGH SPEED INDUCTION MOTORS DAV20B, DAV50B

Built-in squirrel-cage induction motors are designed for turbo compressor drives of climate control systems, fans and others. Motor power and control are performed with a frequency converter.

Induction motors can have a frame design on customer's request, and in this case forced cooling is provided by customer with an external blower fan.

Induction motors with frame have no resonant frequency in the whole operating range of speed changes.

On customer's request induction motors can be supplied with a frequency converter and with pre-set acceleration and brake characteristics, as well as with an embedded temperature detector.

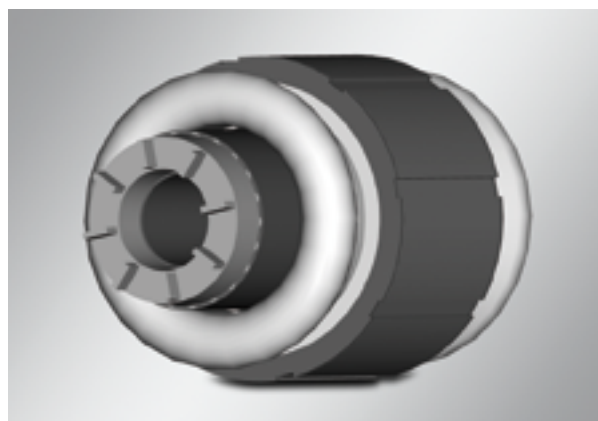

Parameters	Values
Voltage	380 V
Rated speed	20 000 – 30 000 rpm
Speed control range	1 000 – 40 000 rpm
Output power on the shaft	5 – 50 kW
Efficiency	93 %
Operating temperature range	–60 ... +100 °C
Insulation thermal resistance grade	H (200°C)
DAV-20B rotor weight	1.8 kg
DAV-20B motor weight	≤8.5 kg
DAV-50B rotor weight	4 kg
DAV-50B motor weight	≤20 kg



INDUCTION MOTORS FOR CONDENSED GAS TRANSFER PUMP DRIVES ADV355S4

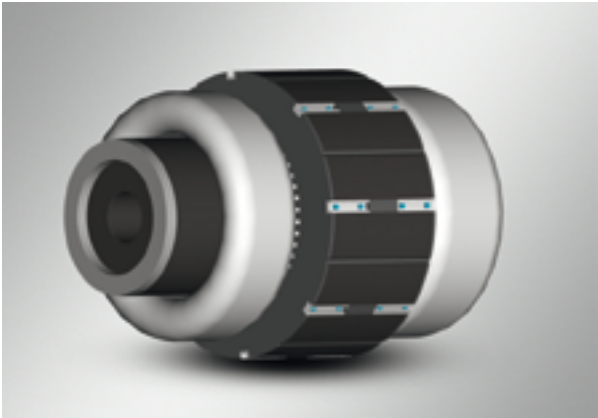

Build-in induction motors are designed for centrifugal condensed gas transfer pump drives.

Induction motors are designed for full dipping operation in condensed natural gas or liquid nitrogen gas at temperature down to -196°C . Motor insulation is low temperature and oil resistant.

Motors are designed for AC power supply of 380 V and frequency of 50 Hz.

Parameters	Values
Output power	200 kW
Synchronous speed	1500 rpm
Input current	350 A
Efficiency	95 %
Power factor	0.9
Operating temperature	-161.5°C
Insulation thermal resistance grade	H (200°C)
Motor weight	≤ 950 kg
Operating mode	continuous duty S1 according to GOST 183
Lifetime	5 years
Outer diameter	690 mm
Max. length	900 mm

INDUCTION MOTORS FOR GEARLESS ELEVATOR DRIVES ADBKH180L12LBU3

Squirrel-cage induction motors are designed for operation with a frequency converter and rotor speed control. The control is provided according to scalar control law. Motors are designed for gearless machines of modern elevators.

Mounting arrangement is on feet with two shaft outlet ends. Traction sheave is mounted directly on the motor shaft. Electromagnetic brakes and speed sensor are mounted on the opposite side of the motor shaft.

Motor cooling is natural convection without a blower fan on the shaft. Temperature protection is built in winding.



Parameters	Values
Rated power on the shaft	6.7 kW
Rated power speed	200 rpm
Speed control range	40-250 rpm or 5-30 Hz
Rated torque	320 N*m
Rated input current	≤20 A
Average lifetime before overhaul	20 000 hours
Insulation thermal resistance grade	F (150°C)
Motor weight	≤220 kg
Winding overtemperature	110°C
Operating mode	intermittent periodic duty S5 according to GOST 183
Frame outer diameter	355 mm
Frame length	450 mm
Max. height	420 mm
Max. length	730 mm

On customer's request induction motor can be manufactured with a different control range, built-in air cooling system (if required), electromagnetic brakes, etc.

ENERGY EFFICIENT INDUCTION MOTORS AIRE

According to the International Energy Agency induction motors of increased energy efficiency together with frequency converters can save about 7% of total world-consumed energy volume. In 2011 it was prohibited to sell electric motors with energy efficiency less than IE2 in the EU countries. After 2015 large sizes motors shall comply with IE3 efficiency class, after 2017 all motor sizes shall meet this requirements.

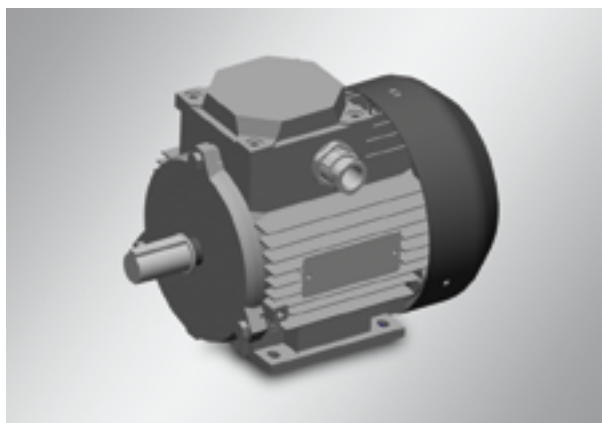

71, 80, 90, 100 — dimension (frame size), mm
 2, 4, 6, 8 — number of poles
 E — energy efficient motors according to the requirements of IEC 60034-30 and IEC 60034-31
 IE3 — energy efficiency according to the requirements of IEC 60034-30
 IE4 — energy efficiency according to the requirements of IEC 60034-31
 IP44 and IP54 — protection degrees according to government standard of Ukraine IEC 60034-5
 IC411 — cooling method according to government standard of Ukraine IEC 60034-6

COMPETITIVE ADVANTAGES:

- savings due to reduction of energy costs, which can be compared with a new motor price of the same frame size
- difference in price between energy efficient and conventional motor will be recovered within 1 year
- high efficiency at partial motor load
- reduction of motor overtemperature to 30°C
- operation at increased power loads
- extension of winding and bearing unit lifetime by 20-35%

Energy efficient motors during its lifetime might help customers to save costs equal to the triple price of a new motor. This provided the basis to start the development of widely-used motor types with higher energy efficiency.

Motors correspond to the requirements of technical specifications 1-00213799-114 for standard motors in all unspecified parameters

Motor type	Power	Efficiency, %	Energy efficiency factor
AIR 71 A2	0.75	80.7	IE3
AIR 71 B2	1.1	82.7	IE3
AIR 80 A2	1.5	84.2	IE3
AIR 80 B2	2.2	85.9	IE3
AIR 80 A4	1.1	84.1	IE3
AIR 80 B4	1.5	85.3	IE3
AIR 80 A6	0.75	78.9	IE3
AIR 80 B6	1.1	81.0	IE3
AIR 90 L2	3.0	87.1	IE3
AIR 90 L4	2.2	86.7	IE3
AIR 90 L6	1.5	82.5	IE3
AIR 100 S2	4.0	88.1	IE3
AIR 100 S4	3.0	87.7	IE3
AIR 100 L6	2.2	84.3	IE3
AIR 100 L2	5.5	89.2	IE3
AIR 100 L4	4.0	88.6	IE3

TESTING CENTRE

The SKB Testing Centre consists of Mechanical and Climate Testing Department and Electric and Vibroacoustic Testing Department, which provide full testing range of electric motors, electric generators and integrated devices.

VIBROACOUSTIC AND ELECTRIC TESTING

- Acceptance, periodic, standard electric and thermal testing of electric motors and generators, electromechanical devices with electric motors and generators of max. 100 kW power and 400 Hz frequency.
- Aerodynamic testing of electromechanical devices with max. 100 kW power and 400 Hz frequency.
- Safety testing of household and similar electric devices.
- Noise testing and research of electric motors and electromechanical devices with max. 100 kW power and 400 Hz frequency.
- Vibration testing and research of electric motors and electromechanical devices with max. 100 kW power and 400 Hz frequency.

MECHANICAL TESTING

Sinusoidal vibration testing of the object with weight up to 200 kg:

- vibration range — 5-35 Hz
- vibration amplitude — max. 5 mm
- maximum acceleration — 5 g

Sinusoidal vibration testing of the object with weight up to 60 kg:

- vibration range — 10-1000 Hz
- vibration amplitude — max. 3 mm
- maximum acceleration — 10 g

Single and repeated impact testing:

- tested object weight — max. 200 kg
- maximum acceleration — 150 g
- pulse duration — max. 20 ms
- pulse repetition frequency — max. 120 strokes per min.



CLIMATE TESTING

High and low ambient temperature testing:

- chamber operating volume — 2.0 m³
- temperature range — from -60 to +100°C
- tested object weight — max. 200 kg
- tested object dimensions — 750 x 750 x 750 mm

Air humidity testing:

- chamber operating volume — 1.0 m³
- operating temperature range — from +20 to +100°C
- relative humidity — 98 ± 2 %
- tested object weight — max. 200 kg
- tested object dimensions — 600 x 600 x 600 mm

Insulating and mechanical testing of:

- copper circular enamelled wires with diameter of 0.28-1.60 mm
- copper winding wires with fiber glass and polyester glass insulation and diameter of 0.315-1.5 mm
- film and film-containing materials.



SERVICE CENTRE

The Service Centre is based on the «SKB Ukrelectromash» production. It provides warranty and post-warranty maintenance of electrical equipment manufactured in-house or by other companies: general-purpose industrial electric motors, special-purpose electric motors, pumping equipment, heating equipment, consumer goods and others.

The «SKB Ukrelectromash» Service Centre provides:

- warranty, post-warranty and out-of-warranty services of equipment (stator rewinding, renewal of passport characteristics and appearance)
- equipment commissioning, mounting and contract supervision
- general and scheduled routine maintenance
- diagnostics, adjustment and upgrading
- reequipment, modification and upgrading
- climate, thermal and vibroacoustic testing
- acceptance, periodic, aerodynamic and electrical testing of electromechanical equipment with electric motors and generators with max. power of 30 kW and max. frequency of 100 Hz
- work on integrated devices at the Customer's premises

Reconditioned products pass testing of all initial parameters and receive guarantee.

MANUFACTURING CAPABILITIES

The Company has a complete technological production cycle, which includes stamping, aluminum casting, machining, assembling and testing. At each production stage the products are technically controlled, if required – with the Customer participation. At the final stage the products pass acceptance testing, and if required — more profound control. Motors are manufactured with the Register of Shipping acceptance and the Customer acceptance for shipbuilding orders from the Navy of Ukraine and Russia.

The SKB manufacturing units involve the following technological processes:

- casting
- stamping
- tooling and machining
- grinding
- winding and insulating
- dipping and painting
- assembling
- quality control acceptance

The casting shop is equipped with electric furnaces for aluminum smelting, a drying oven for mould baking and a vibration table. The Company can design and manufacture models for sand clay casting of all dimension types and maximum rotation axis height of 225 mm.

Stamping and burdening tooling provides manufacture of stator and rotor packages with diameter to 320 mm and length to 800 mm. Stamping equipment consists of different presses, including notching machines, which provide manufacture of magnetic core sheets with different geometry slots, impact frequency of 150 strokes per minute and cutting diameter of max. 500 mm.

Metal-working equipment provides processing of parts and products with outer diameter to 570 mm and length to 1400 mm.

Winding-insulating and dipping-painting units provide manufacturing operations on random winding of any complexity category while working with insulation materials of B, F and H thermal resistance grades.

SKB PRODUCT RANGE

The SKB manufactures over 2 000 product types of own design and every year provides steady production increase due to standard product output growth and development of new competitive products.

Marine low-noise induction motors 2DMSH

- Low noise induction motors — 2DMSH 63-112 and 2DMSH 132-200 — and their modifications.
- Marine three-phase squirrel-cage motors are designed for marine machinery drives (fans, air conditioners, pumps, compressors) for operation in the unrestricted navigation area. Motors 2DMSH 63-112 and 2DMSH 132-200 have a rated power range from 0.06 to 4.0 kW and from 2.2 to 30 kW respectively.



Marine low-noise induction motors 3DMSH

- Induction motors — 3DMSH 63-180 and 3DMSH OV 63-100 — are distinguished from the motors 2DMSH due to a more precision material machining and application of low-noise bearings.
- Induction motors — 3DMSH 63-180, 3DMSH OV 63-100, 3DMSH 90-112 and 3DMSH 132-200 — have a rated power range from 0.12 to 18.5 kW.
- Marine three-phase squirrel-cage induction motors 3DMSHR 160MA4-OM5 are designed for engine-turning gear drives.



Marine low-noise motors 4DMSH

- Marine three-phase squirrel-cage induction motors 4DMSH are designed for operation in the unrestricted navigation area. Motors have a rated power range from 0.12 to 4.0 kW.
- Motors 4DMSH for drives of centrifugal fans, chargers and central air conditioners.
- Motors 4DMSH OV for summer air conditioner drives.
- Motors 4DMSH O for screw fan drives. Induction motors 4DMSH B, 4DMSH 1B and 4DMSH P.
- Induction motor block BDA1,1-OM5 consists of two marine three-phase squirrel-cage induction motors 4DMSH V90SA4-OM5 for vacuum pump block drives and for operation in the unrestricted navigation area. Induction motor block BDA1,1-OM5 has a rated power of 0.55 kW.

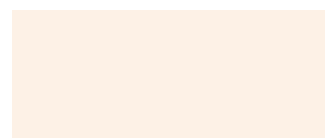

Built-in motors

- Marine built-in three-phase squirrel-cage induction motors AV2K have a rated power range from 0.55 to 7.5 kW and are designed for compressor and oil pump drives.
- Marine built-in three-phase squirrel-cage induction motors 3AVSh132 are designed for gastight compressor drives of electrochemical air revitalization. Induction motors 3AVSh132 have a rated power range from 5.5 to 7.5 kW.
- Built-in three-phase squirrel-cage induction motors 4AVSh are designed for compressor drives. The number of start-ups per hour is no more than 6 uniformly over time. Motors provide both left and right directions of rotation.
- Marine built-in three-phase squirrel-cage induction motors 3AV2K are designed for gastight freon compressor and oil pump drives of refrigerating machines. Induction motors AV2K have a rated power range from 1.5 to 4.0 kW.
- Built-in induction motors DAT 130-250-3 are designed for compressor drives KGBK and BSKA. Motors can operate positively in the following operating environments:
 - halocarbon 12 GOST 19212-87 and oil KhF 12-16 GOST 5546-86
 - halocarbon 22 GOST 8502-93 and oil KhF 22C-16 GOST 5546-86
 - halocarbon 502 in accordance with technical specifications 6-02-1200-84 and oil KhF 22C-16 GOST 5546-86
- Induction motors — DAV80B2BN and DAV132BN are designed for submersible monoblock pumps TsMK, TsMF and GNOM, which pump feces fluid, domestic and industrial waste water. Any mounting arrangement of the motor is available. Rated operating mode is continuous duty. Motors provide both left and right directions of rotation. Motors are mounted in a sealed finned pump housing, which provides motor cooling:
 - open air operation – due to unit design (finning of the pump housing)
 - liquid operation — due to cooling with this liquid

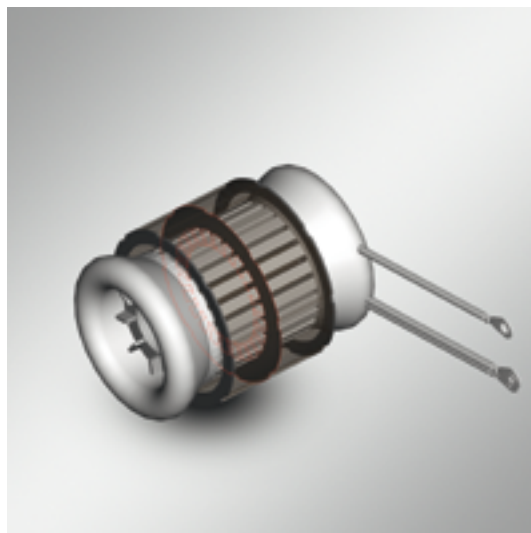

SKB PRODUCT RANGE

Motors with increased reliability and durability

- Induction motors — DMR 71-112 and DMRM 71-112 — for auxiliary machinery drives.
- Induction motors — DMR 71-112 and DMRM 71-112 — with a rated power range from 0.12 to 4.0 kW.
- Induction motors DMR 160MA4-02 for auxiliary machinery drives.
- Induction motors DMR 160MA4-02 with a rated power of 7.5 kW.
- Induction motors — 2DMR90SB2UKhL and 2DMR100L2UKhL — for fan drives and with a rated power range from 1.1 to 2.2 kW.
- Induction motors 2DMR112MA 4/2 UKhL for mobile unit compressor drives.
- Induction motors 2DMR112MA 4/2 UKhL with a rated power of 2.2/3.0 kW.
- Induction motors 2DMShOR112MA2UKhL for axial flow fan drives.
- Induction motors DRO 12-2-02.
- Induction motors DAT 128-250-3 for axial flow fan drives.



Motors with increased speed (400Hz)

- Induction motors DMCh are designed for pump drives, fans and other auxiliary machinery. Induction motors DMCh have a rated power range from 0.18 to 18.5 kW.
- Induction motors of increased speed DChR are designed for pump drives, fans and mobile unit power machinery. Motors DChR have a rated power range from 0.75 to 4.0 kW.
- Induction motors DF and DFO of 00, 0, 1, 2, 3, 4 frame sizes are designed for marine machinery drives (fans, compressors, pumps, converters and others).
- Induction motors of increased speed AOL are designed for general purpose industrial equipment.
- Single-phase squirrel-cage induction motors DFE-51-12 are designed for special machinery drives and only for operation in a sealed metal capsule.



Motors with outer rotor for centrifugal fans

- Marine special-purpose three-phase squirrel-cage induction motors DN 80-100 are designed for centrifugal fan drives of double inlet fans. Design and development work of motors with outer rotor are planned for:
 - DN 112A6 – 2.2 kW
 - DN 132A6 – 3.0 kW

Variable frequency motors

- Variable frequency and increased frequency motors AI40, AI56, AIKh80 and AIKh90 — and their modifications are built-in, open, self-cooling and designed for household appliance drives, for operation on the converter, which converts single-phase AC power supply with frequency of 50 Hz into three-phase with increased frequency of 100 Hz, 200 Hz, 300 Hz.
- Variable speed induction motors — AIKh63, AIKh80 and AIKh112 — are designed for operation in CNC machinery.

Motors for Nuclear Power Plants

- Induction motors — AIRB71A1, AIRB80A1 and AIRB100A1 — for electric drives in containment areas of NPP, with frequency of 50 Hz, for national economy needs and with frequency of 50Hz and 60 Hz.
- Induction motors 4AS71A5-4AS100A5 — for operation in armature drives mounted under the containment vessel of the NPP, which can be located in any climate area in accordance with GOST 15150-69.
- Induction motors — AIR80 A3 and AIR90 A3 — for drives of the equipment located in «clean» rooms and «dirty» box-rooms (out of tight area) of NPP.



Full product range is represented in the Products and Services catalogue and available on our website www.ukrskb.com.ua

LLC «SKB Ukrelectromash»

37, Iskrinskaya Str.
Kharkov, 61001, Ukraine

phone: +38 057 766-25-77

fax: +38 057 732-58-57

info@ukrskb.com.ua

www.upec.ua

www.ukrskb.com.ua

